

Sales@RivetNutUSA.com

*Request your quote with Rivet Nut USA (an operating division of Cardinal Components, Inc.)
Cardinal Components, Inc. is your authorized preferred specialty fastener distributor.*

ISO 9001 CERTIFIED
www.RivetNutUSA.com
(800) 236-3200



RIVKLE® /RIVNUT® 4090

Pneumatic power tool for controlled setting of blind rivet nuts

- Robust construction
- Ergonomic design
- Accommodates varying material thickness



BOLLHOFF

Table of content

SAFETY RECOMMENDATIONS	15
I. PRINCIPLE AND CHARACTERISTICS OF THE DEVICE	15
Objective and use of the device	15
Device principle: Pressure setting	15
Technical characteristics	16
Setting capacity: RIVKLE® M3 to M10 Stainless Steel (max. force 20Kn at 6bar)	16
Tool dimensions	16
Contents of case	16
II. GETTING STARTED	17
Assembling the equipment	17
- Fitting with standard tools (special RIVKLE® pulling rods)	17
- Fitting with general screw DIN912	18
Adjusting the position of the anvil in relation to the pulling rod	19
Connection to the air system	19
Adjusting the setting force	20
III. USAGE	21
Instructions for use	21
Unscrewing button	21
IV. MAINTENANCE	21
Daily/weekly maintenance	21
Occasional maintenance	22
Checking the oil level	22
V. SPARE PARTS LIST	23
Replacement parts	24
VI. DIAGNOSIS AND RECOMMENDATIONS IN CASE OF BREAKDOWN	25
CERTIFICATE OF CONFORMITY	74

Safety recommendations

These instructions must be read before using the tool, or prior to performing maintenance tasks on the equipment. If in doubt, CARDINAL is always at your service.

1. The tool is intended for use with equipment recommended and supplied by CARDINAL.
2. The customer is responsible for training operators in the use and handling of this tool.
3. Any modification made to the tool or maintenance performed on it beyond that mentioned in this document or carried out using other equipment is solely the responsibility of the customer.
4. The equipment must be regularly maintained in accordance with the advice cited in the maintenance section, by a suitably-trained person, particular where disassembly and repair operations are concerned.
5. Disconnect the compressed air supply before adjusting or disassembling the equipment.
6. The operating pressure must not exceed 7 bar. The air must be lubricated.
The use of a regulating / lubricating filter is recommended.
7. The oil level and extent of any wear on the mandrel must be checked regularly.
8. When moving the tool, pick it up in a way which avoids pressing the trigger and accidentally activating the setting cycle.
9. If a RIVKLE® is placed on the mandrel by hand, any contact with moving parts must be avoided by always holding the RIVKLE® on the shaft and never at the ends.
In order to prevent the possibility of finger injury, we recommend positioning the RIVKLE® in the component before introducing the mandrel.
10. The use of gloves is recommended.
11. Do not activate the tool when pointed towards another person. Ensure that no object can become caught in the device mechanism.
12. Ensure that the air inlet and outlet are clean.
13. The operator must not use the tool if a part is missing or inadequately tightened.
14. The tool must be used in accordance with current legislation relating to Ministry of Labour regulations.

English

I. Principle and characteristics of the device

Objective and use of the device

The 4090 tool is used for setting RIVKLE® blind rivet nuts and studs into pre-prepared holes.

Device principle: Pressure setting

This device uses the principle of pressure setting to install RIVKLE®

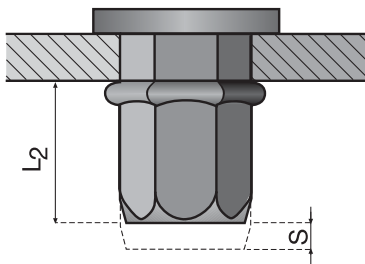

Figure 1 - Stroke setting principle

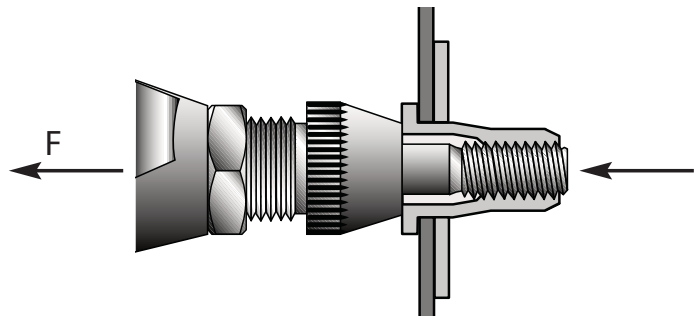

Figure 2 - Pressure setting principle

Sales@RivetNutUSA.com

ISO 9001 CERTIFIED
www.RivetNutUSA.com
(800) 236-3200

Request your quote with Rivet Nut USA (an operating division of Cardinal Components, Inc.)
 Cardinal Components, Inc. is your authorized preferred specialty fastener distributor.

In contrast to the stroke setting principle, which consists of adjusting the stroke of the mandrel (S on the above diagram), the pressure setting principle consists of adjusting the device to a particular force.

The adjusted force corresponds to the pulling force to be exerted in order to set the RIVKLE® (Force F on the figure 2)

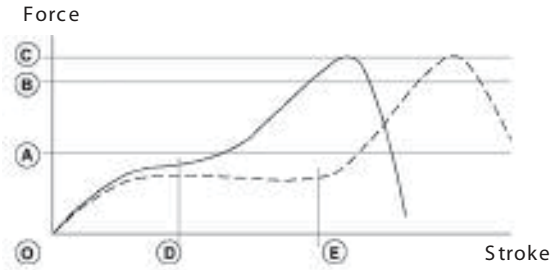

Figure 3 - Force/stroke graph

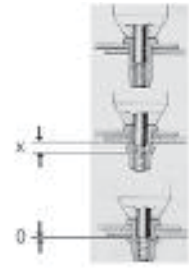

Figure 4

The two curves in the diagram above represent different plate thicknesses.

The advantages of this principle are:

- it is no longer necessary to adjust the tool if there is a variation in material thickness.
- It is possible to re-set or re-start an operation which was unexpectedly interrupted.

Technical characteristics

- Setting capacity: RIVKLE® M3 to M10 Stainless Steel (maximum force: 20kN to 6 bar)
- Maximum stroke: 7 mm
- Operating pressure: 5.5 bar minimum to 7 maximum
- Weight without kit: 2.0 kg
- Air consumption: 8 L
- Noise level: < 70 dB (A)
- Art.: 23615601000/00

Tool dimensions

		M3	M4	M5	M6	M8
Standard Mandrel	A	78	78	78	78	78
	L	32	31	41	42	42
General SCREW	A	59	59	59	59	59
	L	33	34	40	42	47

Table 1

A = Setting nose length

L = Setting tool run-out

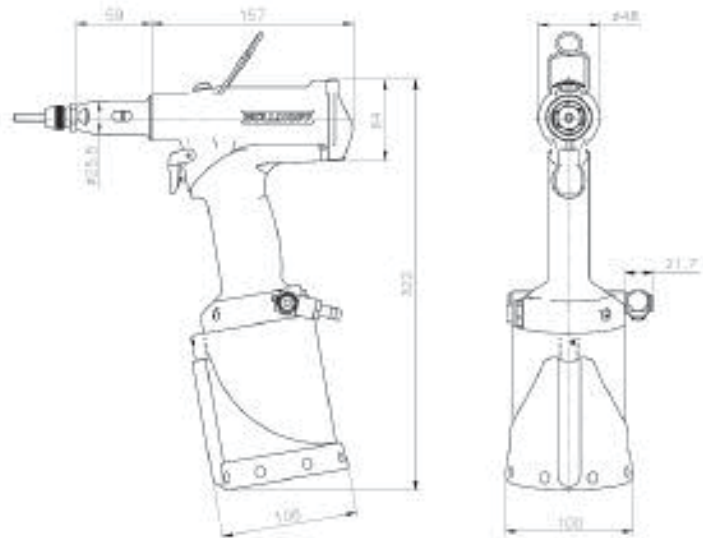

Contents of case 23615601000

- One 4090 pressure setting tool without kit equipped with a setting nose for assembling standard Bollhoff setting tools;
- One instruction manual in six languages;
- One toolkit for adjustment and ongoing maintenance of the equipment



Sales@RivetNutUSA.com

ISO 9001 CERTIFIED
www.RivetNutUSA.com
(800) 236-3200

Request your quote with Rivet Nut USA (an operating division of Cardinal Components, Inc.)
 Cardinal Components, Inc. is your authorized preferred specialty fastener distributor.

II. Getting started

Assembling the equipment

SAFETY: DISCONNECT THE COMPRESSED AIR SUPPLY BEFORE PERFORMING ANY ACTION ON THE 4090 TOOL

You have two assembly options:

- Fitting with special RIVKLE® mandrels (recommended by BOLLHOFF® for extended tool life)
- Fitting with standard capscrews

Fitting with special RIVKLE® mandrels



Figure 6 – Standard tooling

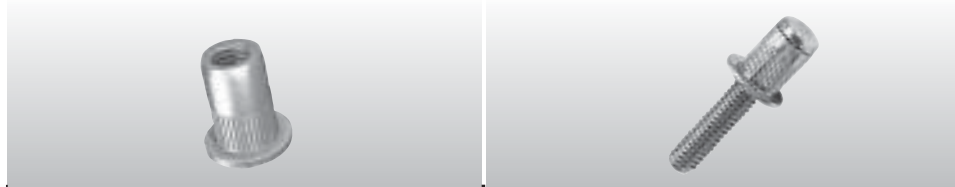

	N°1	N°2	N°1	N°2
M3	236 113 03 020	236 113 03 030	376 113 03 020	376 113 03 030
M4	236 113 04 020	236 113 04 030	376 113 04 020	376 113 04 030
M5	236 113 05 020	236 113 05 030	376 113 05 020	376 113 05 030
M6	236 113 06 020	236 113 06 030	376 113 06 020	376 113 06 030
M8	236 113 08 020	236 113 08 030	376 113 08 020	376 113 08 030
M10	236 113 10 020	236 113 10 030	376 113 10 020	376 113 10 030

Table 2

- Depending on the size of RIVKLE® being set, check that you have the following parts: mandrel (1), anvil and locknut (2) shown in diagram above.
- Clamp the nosecone (5), unscrew the anvil locknut and withdraw the anvil and locknut assembly.
- Depress the pin (9) using a pin-punch, without damaging the ring and completely remove the mandrel.
- Fit the new mandrel (1) and replace the pin (9), ensuring that it is held firmly in place by the ring.
- Tighten the nosecone (5) to 15Nm.
- Screw the new anvil (2) inside the nosecone (5) and lock using the locknut.

Sales@RivetNutUSA.com

ISO 9001 CERTIFIED
www.RivetNutUSA.com
(800) 236-3200

Request your quote with Rivet Nut USA (an operating division of Cardinal Components, Inc.)
 Cardinal Components, Inc. is your authorized preferred specialty fastener distributor.

Fitting with **standard capscrew DIN912:**



Figure 7 - General screw

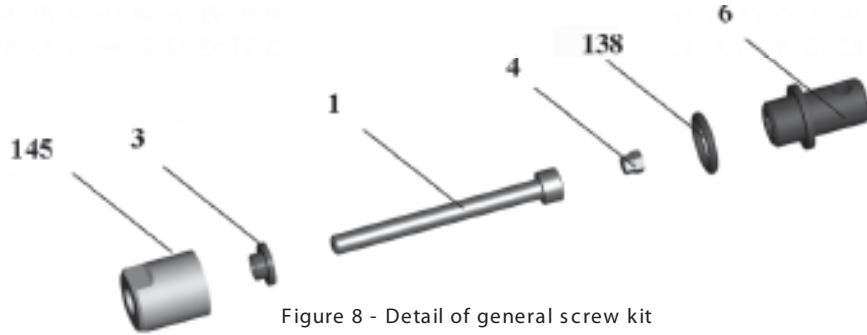

Figure 8 - Detail of general screw kit

	1+2+3+4	1*	2	3	4
M3	236 803 03 000	CHC ISO4762 DIN912 : M3 x 60	236 113 03 030	236 803 03 040	236 803 03 010
M4	236 803 04 000	CHC ISO4762 DIN912 : M4 x 60	236 113 04 030	236 803 04 040	236 803 04 010
M5	236 803 05 000	CHC ISO4762 DIN912 : M5 x 70	236 113 05 030	236 803 05 040	236 803 05 010
M6	236 803 06 000	CHC ISO4762 DIN912 : M6 x70	236 113 06 030	236 803 06 040	236 803 06 010
M8	236 803 08 000	CHC ISO4762 DIN912 : M6 x70	236 113 08 030	236 803 08 040	236 803 08 010

* : 2368030X020 (10 screws)

Table 3

236 803 00 216 = N°145 + 138 + 6

236 803 00 005 = N°5

- Depending on the size of RIVKLE® being set, check that you have the following parts: standard capscrew (1), anvil and locknut (2) washer (3) and hex driver (4) shown in diagram above.
- Loosen the anvil locknut and unscrew the anvil (2).
- Unscrew the nosecone(5).
- Insert the capscrew (1) into the ring (3), which corresponds to the diameter (no ring for M8)
- Locate the hexagonal driver (4) within the head cavity of the screw (1).
- Let the assembly slide into the traction socket (7).
- Replace the nosecone (5).
- Replace the anvil and the locknut (2).

If you already own an OPEN tool, 4080 or 4069, you may re-use your tools.
The items can be ordered from Cardinal using the codes shown in tables 2 and 3.

Sales@RivetNutUSA.com

ISO 9001 CERTIFIED
www.RivetNutUSA.com
(800) 236-3200

Adjusting the position of the anvil in relative to the mandrel

- The position of the anvil depends on the length of the RIVKLE® before setting.
- The position of the anvil should be adjusted as shown in figure 9.
- After adjustment, tighten the anvil locknut (2) to 10 Nm.

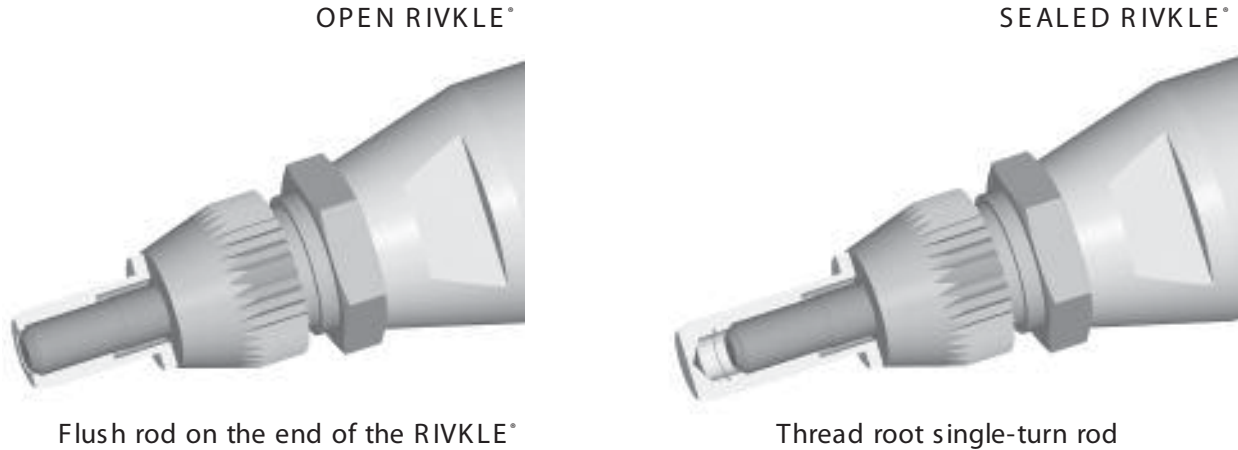

Figure 9 - Adjustment of the anvil position

Connection to the air system

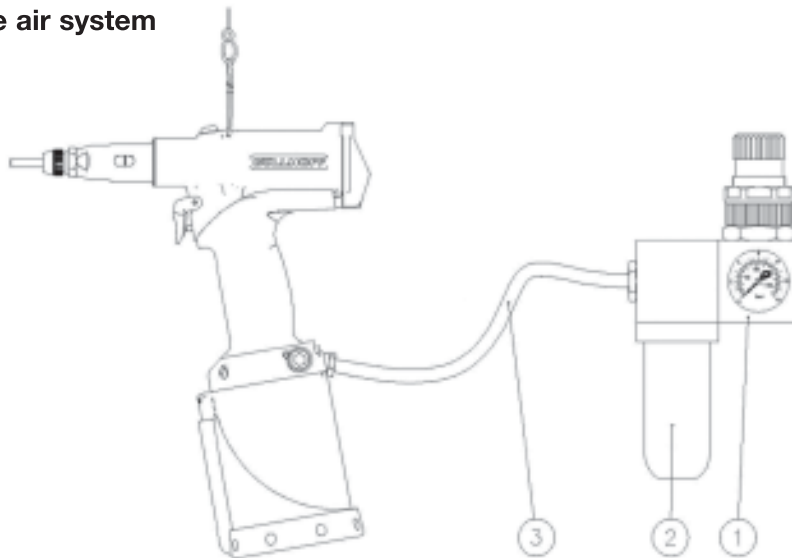

Figure 10 – Air connection

In order to facilitate the integration of the tool, it is possible to fit the air supply connection to the left or right of the pneumatic trough.

All of the tools operate with compressed air, at an optimum pressure of 6 bar.

We recommend the use of air treatment units comprising lubrication, filtering and pressure regulation on the air supply system.

These units should be placed up to three metres from the tool in order to ensure optimum shelf life and minimum maintenance for the tool.

All air hoses MUST have a minimum internal diameter of 6.4mm or ¼ of an inch.

Sales@RivetNutUSA.com

Request your quote with Rivet Nut USA (an operating division of Cardinal Components, Inc.)
Cardinal Components, Inc. is your authorized preferred specialty fastener distributor.

ISO 9001 CERTIFIED
www.RivetNutUSA.com
(800) 236-3200

Adjusting the setting force

- Check that the system pressure is between 5 and 7 bar.
- Connect the pneumatic supply to the tool.
- Before using the tool, adjust the setting force to the minimum level by completely unscrewing the multicoloured cartridge.



WHEN IT IS DELIVERED, THE TOOL IS ALREADY SET TO THE MINIMUM FORCE LEVEL. IT WILL THEREFORE BE NECESSARY TO ADJUST THE TOOL WHEN FIRST USED. EXCESSIVE SETTING FORCE CAN DAMAGE THE THREAD OF THE RIVKLE® AND THE MANDREL OR PREVENT THE MANDREL FROM BEING WITHDRAWN FROM A SET RIVKLE®. WHEN CORRECT SETTING IS OBTAINED, RAISE THE POSITION OF THE MULTICOLOURED ADJUSTING RING AS A ROUGH GUIDE.

- Using a no.5 Allen key, adjust the desired setting force approximately by screwing the multicoloured cartridge in order to make the colour preceding that which is desired disappear.

Adjustment Guide

The colour rings correspond to an approximate setting force. The adjustment guide shown below (fig. 11) will help you to set your tool as accurately as possible.

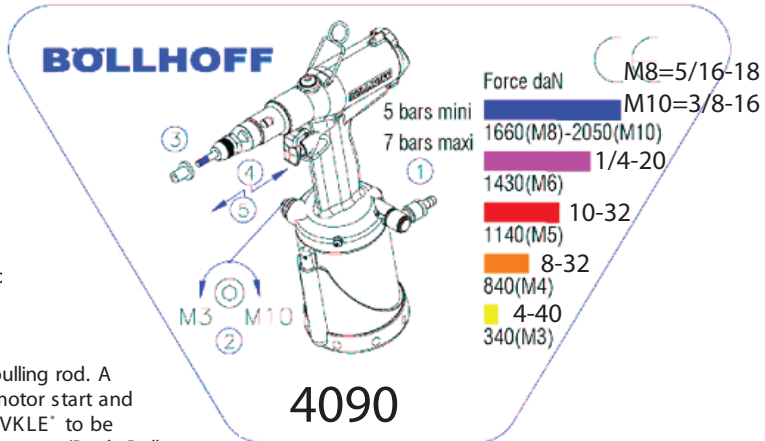

Figure 11 - Adjustment Guide

- Perform a setting test:
- Place the RIVKLE® on the pulling rod. A slight pressure makes the motor start and automatically causes the RIVKLE® to be screwed onto the nose, then stop (Push-Pull System).
- Place the RIVKLE® in the workpiece.
- Press the trigger and hold until the device releases completely. This action sets the RIVKLE® in the workpiece and releases it by unscrewing the pulling rod.



THE TRIGGER MUST BE HELD THROUGHOUT THE DURATION OF THE CYCLE. RELEASING IT WOULD CAUSE NON-COMPLIANT SETTING.

- Next, finely adjust the force by screwing the multicoloured cartridge notch by notch (one notch = 100 N)
- Step by step, test the RIVKLE® setting quality up to the optimum setting.

Sales@RivetNutUSA.com

Request your quote with Rivet Nut USA (an operating division of Cardinal Components, Inc.)

Cardinal Components, Inc. is your authorized preferred specialty fastener distributor.

ISO 9001 CERTIFIED

www.RivetNutUSA.com

(800) 236-3200

III. Usage

The tool can operate in any plane, whether hand-held or suspended.

Instructions for use

- Connect the pneumatic supply to the tool.
- Position the RIVKLE® flange at the end of the mandrel. A slight pressure will start the motor and automatically spin the RIVKLE® up to anvil face, then stop (Push-Pull System).
- Place the RIVKLE® in the workpiece.
- Press the trigger and hold until the device releases completely. This action sets the RIVKLE® in the workpiece and releases it by unscrewing the mandrel.



THE TRIGGER MUST BE HELD THROUGHOUT THE DURATION OF THE CYCLE. RELEASING IT WOULD CAUSE NON-COMPLIANT SETTING.

Unscrewing button

- In the event of problems unscrewing the mandrels, the 4090 is equipped with an unscrewing button located on the top of the air reservoir. To wind out the mandrel independent of the normal operating cycle, keep the button depressed until the mandrel withdraws completely.

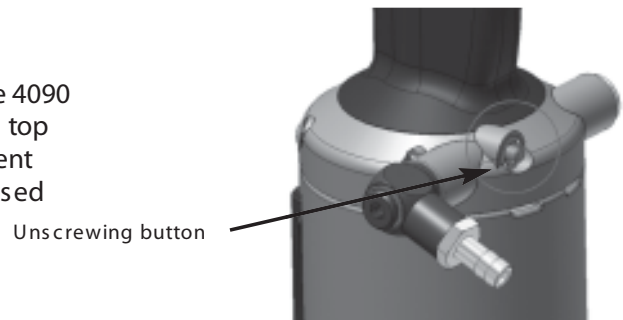

Figure 12 - Unscrewing

IV. Maintenance

Daily/weekly maintenance

OPERATION	FREQUENCY
Check that the fitted tool is suitable for your RIVKLE®.	Upon each adjustment
Check that the tool's setting force is correct for setting the selected RIVKLE® (see pressure adjustment).	Once a day
Check the condition of the pulling rod and change it if necessary.	Once a day
Check that the "screwing - setting - unscrewing" actions operate via pressure on the rod and the trigger, without RIVKLE®	Once a day
Check that the first RIVKLE® is screwed up to the anvil.	/
Always keep the pulling rod perfectly perpendicular to the support.	/
Oil the threaded rod.	Every 300 RIVKLE®
After use, protect the threaded rod with a RIVKLE®	/
Check the air inlet pipe and the connection for leaks	Once a day Insulate using Teflon (connection), or change the pipe
If there is no filter, drain and oil the air supply system	Once a day

Table 4

Sales@RivetNutUSA.com

Request your quote with Rivet Nut USA (an operating division of Cardinal Components, Inc.)
Cardinal Components, Inc. is your authorized preferred specialty fastener distributor.

ISO 9001 CERTIFIED
www.RivetNutUSA.com
(800) 236-3200

Occasional maintenance



MAINTENANCE OF THE TOOLS MUST BE PERFORMED BY QUALIFIED PERSONS. THE OPERATOR MUST NOT PARTICIPATE IN THE MAINTENANCE OR REPAIR OF THE TOOL UNLESS HE OR SHE HAS RECEIVED THE APPROPRIATE TRAINING.

The pneumatic supply must be disconnected before performing any maintenance or disassembly.

Every 500,000 cycles, the tool must be completely disassembled and any worn or damaged parts replaced. It is also recommended to change all of the parts contained in the repair kit.

It is recommended to carry out disassembly in a clean working environment.

Maintenance kit

In order to facilitate your maintenance, we recommend using special tools in order to avoid damaging your tool

Repair kit	N° 236 156 0220
Special maintenance tools	On request

The repair kit contains:

- Pneumatic and hydraulic seals;
- Push Pull mandrel
- Rear cover assembly
- Trigger assembly
- Cycle start assembly
- Unscrewing assembly
- Cycle valve assembly
- Pressure adjustment assembly
- Push Pull assembly

Checking the oil level



Use only HYDROLUB H68 Condat oil or similar.

- Disconnect the compressed air supply.
- Remove the upper oil fill screw (7) & the screw (8).
- Check the oil level in the hole (7) and top up the oil until it reaches the bottom of the thread in the hole.
- Replace the screw (7) with the seal (8).
- Reconnect the compressed air supply and check the setting pressure after several manoeuvres.
- In case of insufficient stroke, repeat the operation.

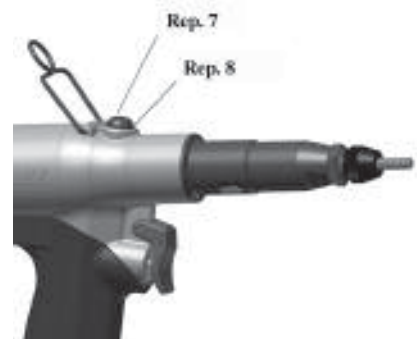

Figure 13 - Oil level

Sales@RivetNutUSA.com

Request your quote with Rivet Nut USA (an operating division of Cardinal Components, Inc.)
Cardinal Components, Inc. is your authorized preferred specialty fastener distributor.

ISO 9001 CERTIFIED
www.RivetNutUSA.com
(800) 236-3200

V. Spare parts list

English

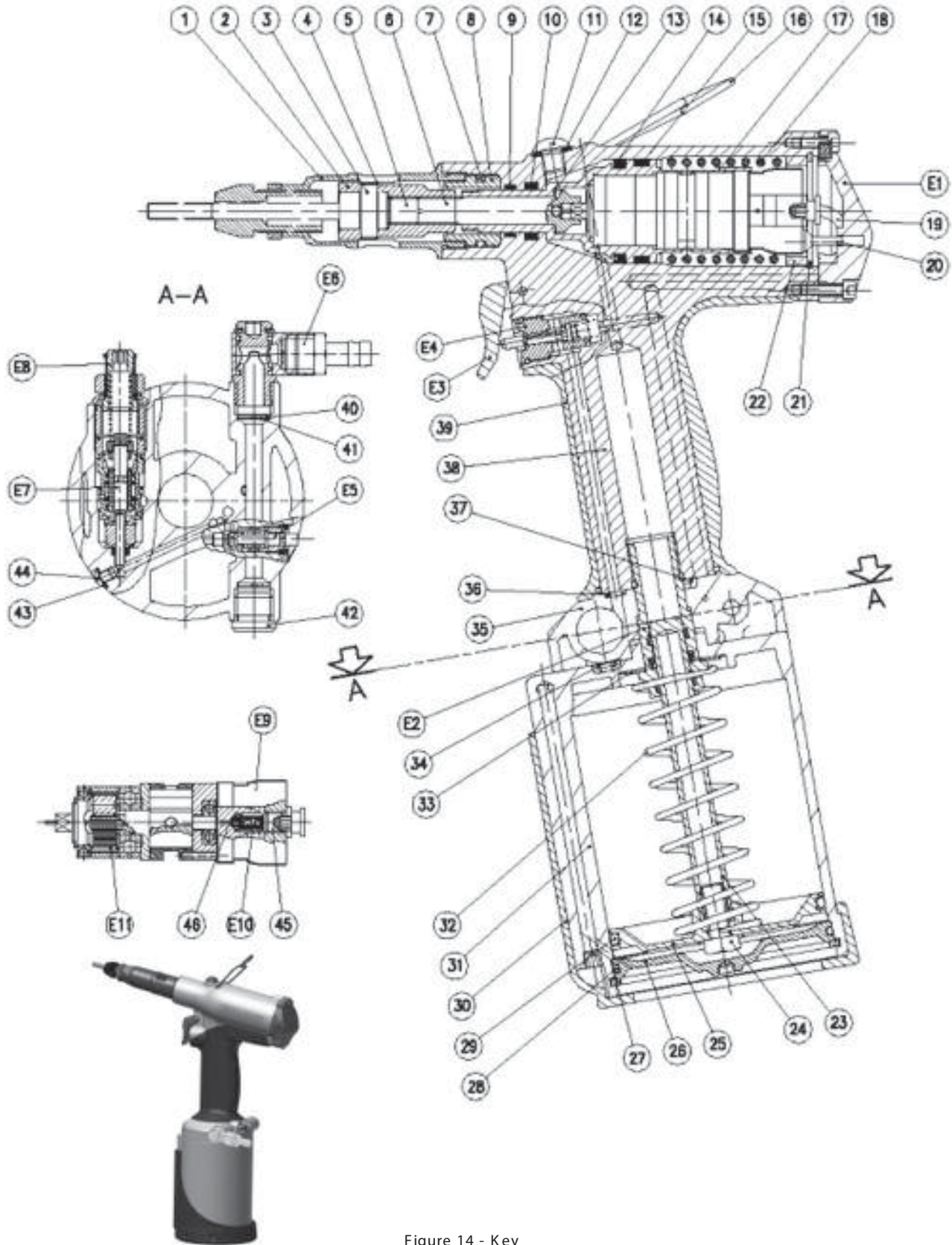

Figure 14 - Key

Sales@RivetNutUSA.com

ISO 9001 CERTIFIED
www.RivetNutUSA.com
(800) 236-3200

Request your quote with Rivet Nut USA (an operating division of Cardinal Components, Inc.)
Cardinal Components, Inc. is your authorized preferred specialty fastener distributor.

	DESCRIPTION	Qty	REFERENCE
1	Nose	1	23680300400
2	Pulling stud	1	23680300007
3	Pin	1	23680300009
4	Ring	1	23680300008*
5	Screw M10	1	23680300010
6	Drive shaft	1	23680300209
7	Seal	1	23615600007
8	Stroke stop	1	28252128007
9	Guide ring	1	23680300015
10	Seal	1	23680300017*
11	M8 screw	1	23680300018
12	D8 BS ring	1	23680300019*
13	Support washer	1	23680300020
14	Seal	1	23680300022
15	Guide ring	1	23680300024
16	Ring	1	23680300014
17	Receiver piston	1	23680300025
18	Spring	1	23680300026
19	Pneumatic tube	2	23615600019
20	Anti-rotation shaft	1	23615600020
21	Circlip	1	23615600021
22	Spacer	1	23615600022
23	Output piston	1	23680300060
24	M8 screw	1	23680300067
25	Pneumatic piston	1	23680300066
26	Base	1	23680300065
27	Circlip	1	23680300063
28	Seal	1	23680300062*
29	Seal	1	23680300061*
30	Lower protection	1	23680300064
31	Pneumatic trough	1	23615600031
32	Spring	1	23680300058
33	Support washer	1	23615600033
34	Seal	1	23615600034*
35	Distributor	1	23615600035
36	Seal	1	23615600036*
37	Seal	1	23615600037*
38	Body	1	23615600038
39	Plastic handle	1	23680300071
40	Elastic ring	2	23615600040
41	Filter	2	23615600041
42	Plug	1	23615600042
43	BS ring	1	23615600043*
44	Screw	1	23615600044
45	Plug	1	28252128029
46	Push Pull rod	1	28252128032*
E1	Rear cover assembly	1	23615600201
E2	Bearing assembly	1	23615600202
E3	Trigger assembly	1	23615600203
E4	Cycle start assembly	1	23615600204*
E5	Unscrewing assembly	1	23615600205*
E6	Connection assembly	1	23615600206
E7	Cycle valve assembly	1	23615600207*
E8	Pressure adjustment assembly	1	23615600208
E9	Distributor assembly	1	23615600209
E10	Push Pull assembly	1	23615365807*
E11	Motor assembly	1	23680300201

*are in repair kit 236 156 0220

Table 5

Sales@RivetNutUSA.com

ISO 9001 CERTIFIED
www.RivetNutUSA.com

Request your quote with Rivet Nut USA (an operating division of Cardinal Components, Inc.)
 Cardinal Components, Inc. is your authorized preferred specialty fastener distributor.

(800) 236-3200

VI. Diagnosis and recommendations in case of breakdown

Before performing any operation, check the oil level and air supply pressure (between 5 and 7 bar)

English

PROBLEM	PROBABLE CAUSE	SOLUTION
Thread of the pulling rod damaged. Difficulty screwing and unscrewing.	1 - Setting thickness incompatible with the RIVKLE®. 2 - Setting stroke too long. 3 - Tool held incorrectly during setting. 4 - Thread of the pulling rod damaged.	1 - Check the setting range on the RIVKLE® catalogue. 2 - Repeat the setting test in accordance with the instructions. 3 - Keep the pulling rod perpendicular to the support face. 4 - Change the rod in accordance with the instructions.
RIVKLE® tapping faulty after setting.	1 - Thread of the pulling rod damaged. 2 - RIVKLE® not completely screwed on the pulling rod. 3 - Setting force too high. 4 - Setting thickness incompatible with the RIVKLE®.	1 - Change the rod in accordance with the instructions. 2 - Adjust the position of the anvil in accordance with the instructions. 3 - Repeat the setting test in accordance with the instructions. 4 - Check the setting range on the RIVKLE® catalogue.
The RIVKLE® rotates in its housing.	1 - Setting thickness incompatible with the RIVKLE®. 2 - The head of the RIVKLE® is not in contact with the anvil during setting. 3 - Setting force too low.	1 - Check the setting range on the RIVKLE® catalogue. 2 - Ensure that contact is made during screwing. 3 - Repeat the setting test in accordance with the instructions.
The tool is not unscrewing after the end of the setting travel	1 - Compressed air pressure insufficient, 2 - Lack of oil. 3 - Engine problem.	1 - Check the supply pressure. 2 - Add oil in accordance with the instructions in chapter IV. 3 - Check that the motor rotates when the tool is empty.
Screwing does not work.	1 - Absence of air on the tool. 2 - Push Pull valve poorly adjusted.	1 - Check that the tool is supplied with compressed air. 2 - Adjust the Push Pull valve
The setting stroke is zero.	1 - Adjustment cartridge at minimum 2 - Lack of oil in the tool.	1 - Adjust the setting force. 2 - Top up the oil.
The tool screws continuously.	1 - Push Pull valve poorly adjusted	1 - Adjust the Push Pull valve
Unscrewing does not occur (took stuck on the part).	1 - RIVKLE® tapping or pulling rod thread damaged. 2 - Lack of oil. 3 - Not enough air pressure.	1 - To release the device: - place the pin (9) opposite a light on the nose (5) and release it; - unscrew the anvil (2); - release the tool. 2 - Add oil in accordance with the instructions in chapter IV. 3 - Check the air pressure.
The tool takes some time to unscrew after the end of setting.	1 - The setting force is too high 2 - Lack of oil.	1 - Reduce the setting force using a n° 5 Allen key. 2 - Add oil in accordance with the instructions in chapter IV.

Table 6

Sales@RivetNutUSA.com

Request your quote with Rivet Nut USA (an operating division of Cardinal Components, Inc.)
 Cardinal Components, Inc. is your authorized preferred specialty fastener distributor.

ISO 9001 CERTIFIED
www.RivetNutUSA.com
(800) 236-3200