

RIVETKING® COPPER BLIND RIVET

CBS SERIES • RIVET: COPPER • MANDREL: STEEL/COPPER PLATED

STANDARD BLIND RIVETS

RIVETKING® OFFERS COPPER RIVET BODIES WITH STEEL/ COPPER PLATED MANDREL. The steel mandrel configuration is best for gutter or roofing applications or in electronic or decorative applications where cost is of concern. CBS series rivets meet or exceed IFI 114 specifications.

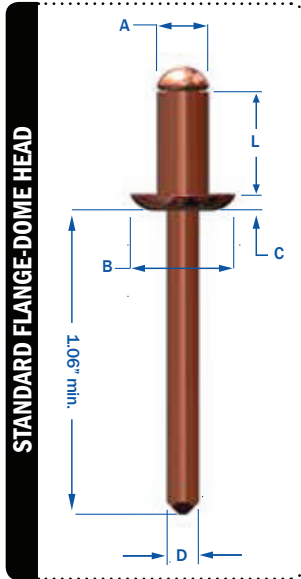

DIA.	PART NUMBER	GRIP RANGE	HOLE SIZE (DRILL #)	A			MANDREL DIA.	STRENGTH		WEIGHT PER M
				RIVET LENGTH	HEAD DIA.	HEAD HEIGHT		SHEAR	TENSILE	
1/8"	CBS - 42	.020 - .125	.129 - .133 (#30)	.275	.250	.040	.076			3.1
	CBS - 43	.126 - .187		.337						3.4
	CBS - 44	.188 - .250		.400						3.4



RIVETKING® COPPER/ BRASS BLIND RIVET

CBB SERIES • RIVET: COPPER • MANDREL: BRASS

RIVETKING® OFFERS COPPER RIVET BODIES WITH A SOLID BRASS MANDREL. The solid brass mandrel configuration is used in electronics applications where superior conductivity is required or in decorative applications where superior corrosion protection is required. CBB series rivets meet or exceed IFI 114 specifications.

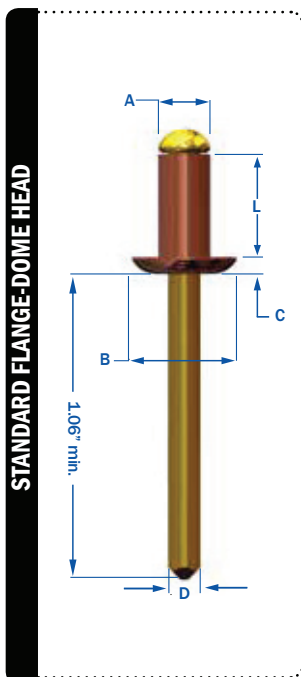

DIA.	PART NUMBER	GRIP RANGE	HOLE SIZE (DRILL #)	A			MANDREL DIA.	STRENGTH		WEIGHT PER M
				RIVET LENGTH	HEAD DIA.	HEAD HEIGHT		SHEAR	TENSILE	
1/8"	CBB - 42	.020 - .125	.129 - .133 (#30)	.275	.250	.040	.076			3.1
	CBB - 43	.126 - .187		.337						3.4
	CBB - 44	.188 - .250		.400						3.4

