

BÖLLHOFF Product data sheet

RIVKLE® Standard blind rivet studs

Steel zinc-plated | Flat head | Knurled | Cylindrical

Note: Thread according to ISO 6h (ISO 68-1) - Corrosion resistance 400 h salt spray

Technical information can be found on the last page.



Diameter (d)	Article number	Drilling diameter d nominal size	B	E nominal size	L ₁	L ₂	e		S		
							min.	max.		min.	max.
M 5	37227050110	7	10	1	11.2	5.0	0.5	3	S = 5.0 - e	7.5	12.0
	37227050115									12.5	17.0
	37227050120									17.5	22.0
	37227050125									22.5	27.0
M 6	37227060115	9	13	1.5	14.2	8.5	0.5	3	S = 5.2 - e	14.0	18.5
	37227060120									19.0	23.5
	37227060125									24.0	28.5
M 8	37227080115	11	16	1.5	15.6	8.5	0.5	3	S = 5.7 - e	13.5	18.0
	37227080120									18.5	23.0
	37227080125									23.5	28.0

The setting process

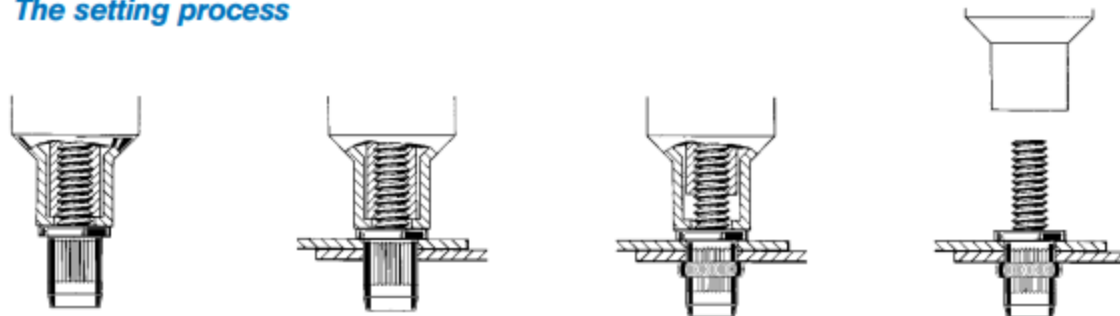

All technical data refer to the measure mm

Sales@RivetNutUSA.com

Request your quote with Rivet Nut USA (an operating division of Cardinal Components, Inc.)

Cardinal Components, Inc. is your authorized preferred specialty fastener distributor.

ISO 9001 CERTIFIED

www.RivetNutUSA.com

(800) 236-3200

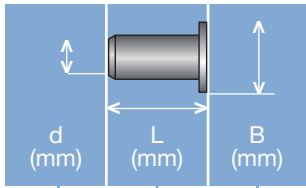

Head diameter
Overall length
Thread size

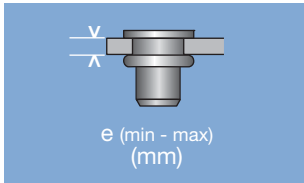

Grip range

Defines the range of total thickness of the customers part (even if it consists of more than one layer)

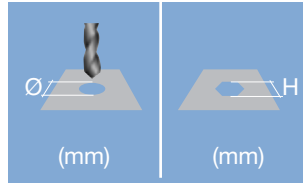

Hole geometry

If round → diameter
 If hexagonal → width across flats

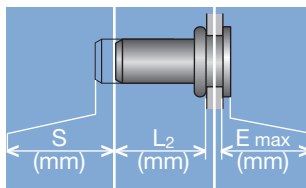

Head projection after setting

Variable according to the application (setting load, material substrate, etc.)

Blind side projection after installation

Defines the clearance needed on the blind side (cannot be used for quality control)

Setting stroke

Difference of total length before and after installation

RIVKLE® Nut

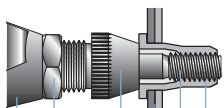

RIVKLE® Stud

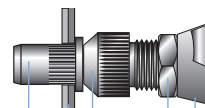

- RIVKLE®
- Mandrel*
- Customers part
- Anvil*
- Counter nut
- Setting tool

in accordance to chosen RIVKLE®

All technical data refer to the measure mm

Sales@RivetNutUSA.com

ISO 9001 CERTIFIED

www.RivetNutUSA.com

(800) 236-3200

Request your quote with Rivet Nut USA (an operating division of Cardinal Components, Inc.)

Cardinal Components, Inc. is your authorized preferred specialty fastener distributor.



Böllhoff Group · Archimedesstr. 1-4 · 33649 Bielefeld · Phone: +49 521 4482-1387 · fat@boellhoff.com · eshop.boellhoff.de/en/home

This document was generated automatically. Subject to technical changes and errors. Distribution as well as duplication of this document, its utilisation and communication of its content only permitted with express consent.